

Feb. 13, 1951

E. SAARINEN
SHAPED CHAIR

2,541,835

Filed Dec. 4, 1948

3 Sheets-Sheet 1

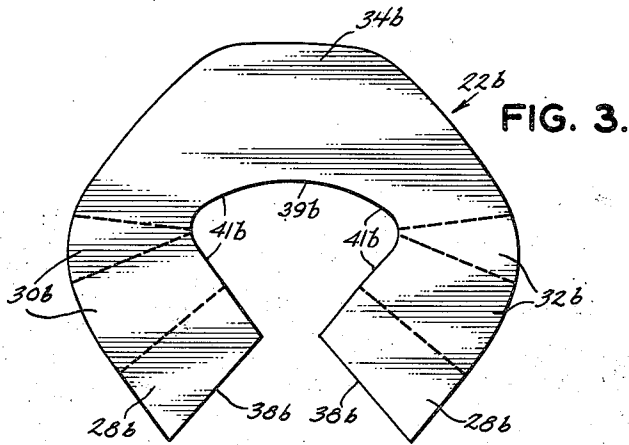

FIG. 3.

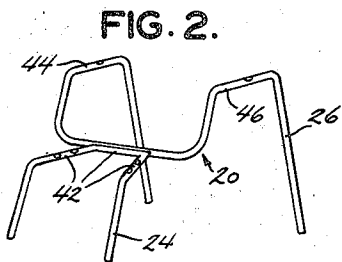

FIG. 2.

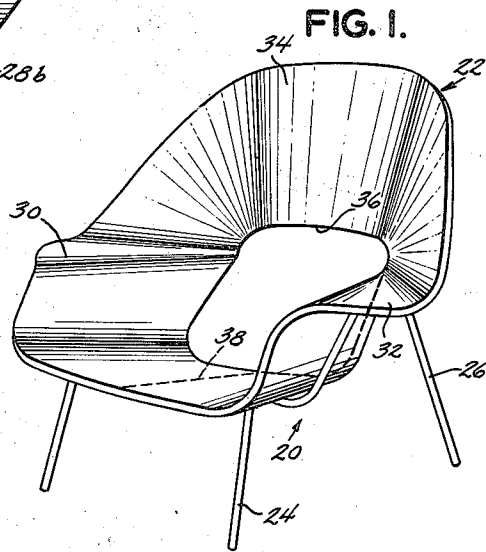

FIG. 1.

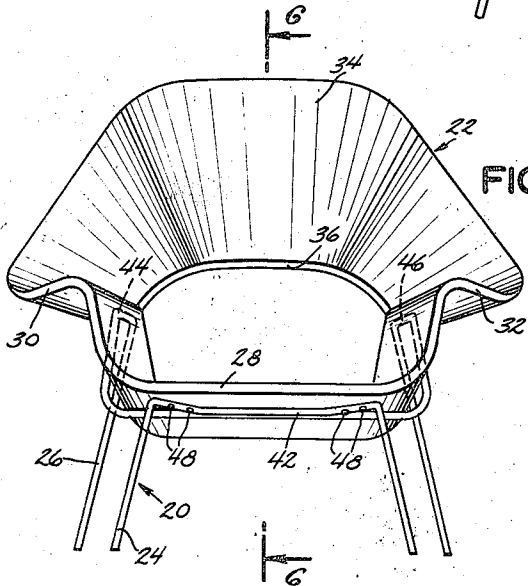

FIG. 4.

INVENTOR.
EERO SAARINEN
BY *[Signature]*
ATTORNEY

Feb. 13, 1951

E. SAARINEN
SHAPED CHAIR

2,541,835

Filed Dec. 4, 1948

3 Sheets-Sheet 2

FIG. 5.

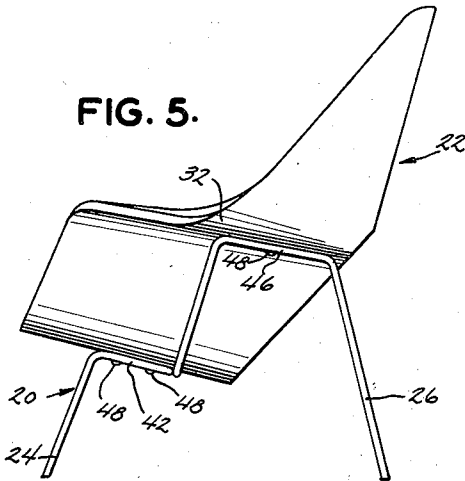

FIG. 6.

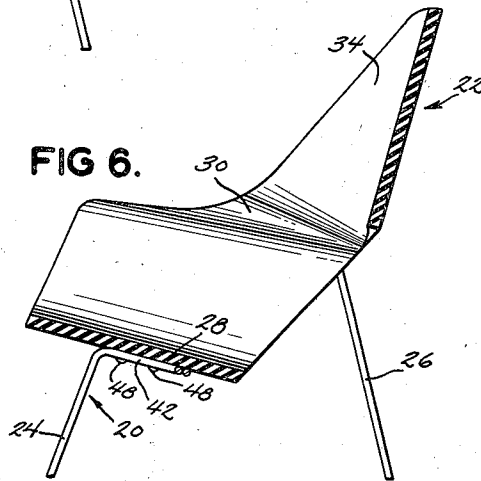
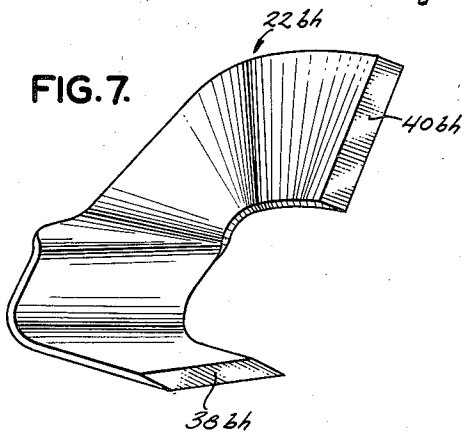

FIG. 7.



INVENTOR.
EERO SAARINEN
BY
[Signature]
ATTORNEY

Feb. 13, 1951

E. SAARINEN
SHAPED CHAIR

2,541,835

Filed Dec. 4, 1948

3 Sheets-Sheet 3

FIG. 8.

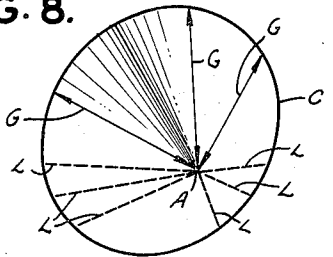

FIG. 9.

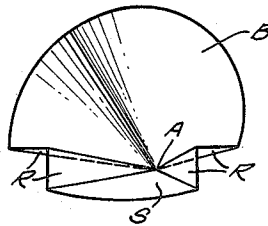

FIG. 10.

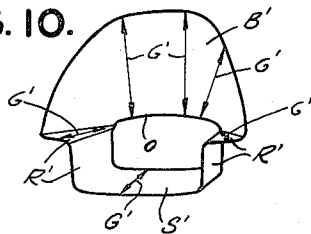

FIG. 11.

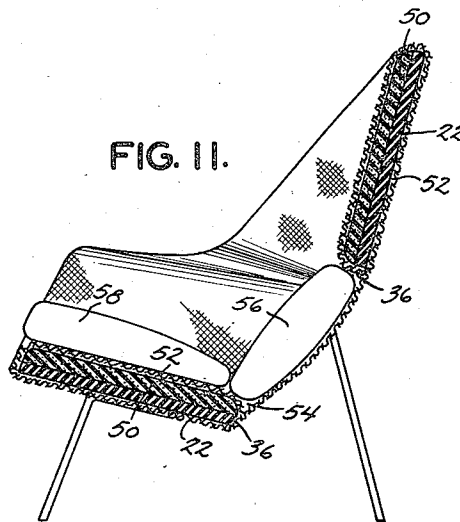
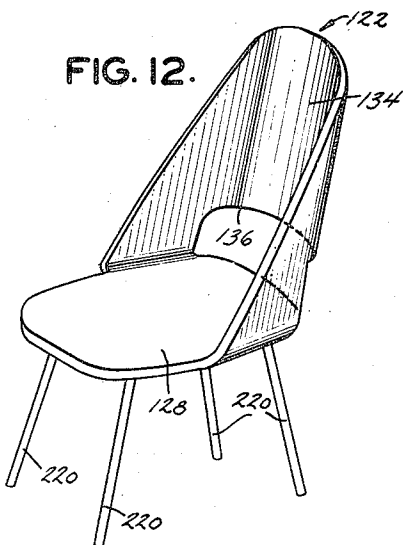

FIG. 12.



INVENTOR.
EERO SAARINEN

BY

ATTORNEY

UNITED STATES PATENT OFFICE

2,541,835

SHAPED CHAIR

Eero Saarinen, Bloomfield Hills, Mich., assignor
to Knoll Associates, Inc., New York, N. Y.

Application December 4, 1948, Serial No. 63,460

17 Claims. (Cl. 155—193)

1

The present invention relates to articles of furniture, and more particularly to an article of furniture, wherein the seat and the back-rest form portions of a shell-like body.

An object of the present invention is to provide an article of furniture wherein the shell-like body containing its seat and back-rest is free from compoundly curved surfaces presenting two-dimensional curves.

A further object of the present invention is to provide an article of furniture, the shell-like body of which containing its seat and back-rest may be readily upholstered without the use of gussets.

Still another object of the present invention is to improve on the art of articles of furniture as now ordinarily made.

With the above and other objects of the invention in view, the invention consists in the novel construction, arrangement and combination of various elements and parts as described herein-after and set forth in the claims hereof, certain embodiments of the same being described in the specification and being illustrated in the accompanying drawings forming part of this specification, wherein:

Fig. 1 is a perspective view of a chair according to the invention,

Fig. 2 is a perspective view of the support carrying the shell-like main body of the chair shown in Fig. 1,

Fig. 3 is a top plan view of a blank which may be used for the manufacture of the shell-like main body of the chair shown in Fig. 1,

Fig. 4 is a front elevational view of the chair shown in Fig. 1,

Fig. 5 is a side elevational view of the chair shown in Fig. 1,

Fig. 6 is a vertical sectional view taken on line 6—6 of Fig. 4,

Fig. 7 is a perspective view of a blank bent into shape so as to form one half of the shell-like main body of a chair according to the invention,

Figs. 8-10 are diagrammatical illustrations of the development of the shell-like main body of a chair according to the invention from a cone,

Fig. 11 is a vertical sectional view similar to that shown in Fig. 6, wherein, however, the shell-like main body of the chair is provided with upholstery, and

Fig. 12 is a perspective view of a different embodiment of a chair according to the invention.

Referring now to Figs. 1, 2 and 4-6, 20 generally indicates a cradle-like support carrying the shell-like main body 22 of a chair.

2

As best shown in Fig. 2, the cradle-like support 20 is made of two rods or tubular elements 24 and 26 bent in suitable manner and connected with each other at their center portion by welding or in any other suitable way.

The shell-like main body 22 comprises a seat-portion 28, two arm rests 30 and 32 and a back-rest 34. Furthermore, said shell-like body 22 is provided with an aperture 36 in its center-portion. The shell-like body 22 is of substantially uniform thickness throughout.

According to a characteristic feature of the invention, the surface of each area of the shell-like body 22 adjacent to said aperture 36 is traced by a straight-line generatrix whether the area, for example the area of the back-rest 34, is curved or whether the area, for example the upper surface of the arm-rests 30 and 32, is substantially straight. Therefore, the overall surface of the shell-like body 22 is free from compoundly curved surfaces. Insofar as the shell-like body includes curved surfaces, they present unidimensional curves. For a better understanding of this characteristic feature of the shell-like body 22 of an article of furniture according to the invention, reference is had to Figs. 8-10 which illustrate the development of the shell-like body from a cone.

As a matter of fact and as illustrated by Fig. 8, the surface area of a cone C is traced by a plurality of generatrices G, all of which emanate from the apex A of the cone.

Now if such a cone C should be deformed into a shell-like body free from compoundly curved surfaces, i. e., into a shell-like body wherein the surfaces of all its areas are traced by straight-line generatrices and the curved surfaces present unidimensional curves, all of its creases must coincide with a generatrix emanating from its apex A. For example, if such a cone C should be deformed into a shell-like body free from compoundly curved surfaces and of a shape as shown in Fig. 9, the cone C would have to be creased at the lines L (see Fig. 8). The resulting shell-like body shown in Fig. 9 with a seat-surface S, arm rest surfaces R and a back-rest surface B, however, would be impractical for use as a member of a chair, as all of its creases are directed towards the apex A. In this way, for example, the seat becomes too narrow at its rear portion. However, the cone C of Fig. 8 can be developed into a practical shape as shown in Fig. 10, if a portion of the cone around its apex is cut out. Then the cone C may be deformed in such a way that the surfaces of all of its curved or straight areas S', R', B' (see Fig. 10) adjacent

3

to the cut-out aperture or opening O are traced by straight-line generatrices G' emanating from an edge of said aperture or opening O. Thus, the shell-like body shown in Fig. 10, for example, is free from compoundly curved surfaces and, at the same time, gives sufficient room to accommodate comfortably the body of a person. Curved surfaces of the shell-like body shown in Fig. 10 being conically shaped present unidimensional curves. As may be gathered from Fig. 10, the generatrices G' do not have a point of intersection common to all of them, contrary to the shell-like body shown in Fig. 9. All compoundly curved surfaces, such as spherically shaped surfaces which would be caused by the direction of the generatrices G' in the shell-like body shown in Fig. 10 are eliminated by the arrangement of the aperture or opening O which is at the place where otherwise compoundly curved surfaces would be found.

In a practical manner, the shell-like body 22 of the chair shown in Figs. 1 and 4-6 may be made from a band-like blank 22b of sheet material having a converging cut-out between its edges 38b, as shown in Fig. 3. Said cut-out converges from the exterior of the blank toward its center and merges into a single aperture having side edges 41b at first diverging away from and then converging toward the center of the blank; the inner edge 39b of said aperture connecting its side edges 41b is on the inner side adjacent the solid portion of the blank outside the space embraced by said side edges. The sheet material of the blank may consist of a plastic or plywood or metal or any other bendable material. The blank 22b is bent in a suitable form into the desired shape of the shell-like body 22. The surfaces of its flat and/or curved areas adjacent to the aperture 36 are traced by straight-line generatrices, the curved surfaces presenting unidimensional curves. Upon suitable shaping of the blank 22b, the edges 38b thereof contact each other, the areas 28b form the seat portion, the areas 30b and 32b form the arm-rests and the area 34b forms the back-rest of the shell-like body 22. In the finished product, the contacting edges 38b of the blank 22b are connected with each other at the seam 38. This connection may be obtained by mechanical means, such as screws, or by the use of an adhesive, such as glue, or by a fusing process in case a thermoplastic material is used, or by any other suitable means.

Instead of bending the blank 22b by means of a form into the desired shape, its various areas could also be bent, one after the other, by suitable means into the shape desired.

Furthermore, instead of using a single blank 22b as shown in Fig. 1, it would also be possible to use several sectional blanks, for example two halves and bending each half either by a form or by other means into the desired shape as shown, for example, in Fig. 7. According to Fig. 7 the band-like blank 22bh of sheet material used for forming one half of the shell-like body 22 of a chair according to the invention is shaped in such a way that its areas obtain the desired shape and that it is provided with beveled joining edges 38bh and 40bh which in the final product may overlap corresponding beveled adjoining edges of the other half not shown in Fig. 7. The two halves may be connected with each other at said beveled joining edges by means of an adhesive or screws or in any other suitable manner. Preferably, the band-like blank 22bh of bendable sheet material is brought into the desired shape

4

by bending same over a mandrel, which may be heated.

Furthermore, the shell-like body 22 of a chair according to the invention could also be made by placing plastic material into a form or mold of suitable shape and shaping said plastic material therein. In such a case, an integral seamless shell-like body would be obtained.

As may be gathered from Figs. 1-6, the cradle 20 is shaped in such a way that its center portion 42 (see Figs. 2, 4, 5 and 6) supports the seat-portion 28 of the shell-like body 22 and that its upper rear portions 44 and 46 (see Figs. 2, 4 and 5) support the laterally and outwardly projecting portions of the arm-rests 30 and 32. Preferably, the remaining portions of the cradle 20 are not in engagement with the shell-like body 22. Thus, the shell-like body 22, which may not be entirely rigid in itself, may give to a certain extent under the load of an occupant and is yet sufficiently supported. The shell-like body 22 may loosely rest on the cradle 20 or may be attached to the latter by means of screws 48 as shown in the drawings.

As mentioned above, the shell-like body 22 of a chair according to the invention is free from compoundly curved surfaces. This feature facilitates to a great extent the upholstering of such a chair, which can be done without the use of gussets.

Fig. 11 illustrates a chair according to the invention wherein the shell-like body 22 is provided with upholstery comprising a layer of foam rubber 50 or the like and a layer of fabric 52. A portion of said layer of fabric covers the aperture 36 at the outside of the article whereby a recess 54 is formed, capable of receiving a cushion 56 and holding same in place. The chair shown in Fig. 11 is provided with another cushion 58 placed on the seat-section of the shell-like body 22.

Of course, if desired, the upholstery of the shell-like body 22 of a chair according to the invention may be omitted and a piece of flexible material, such as fabric or a flexible plastic or the like may be attached to the article for merely covering the aperture 36.

It is understood that the shape of the shell-like body 22 shown in the drawings represents only an example. The shell-like body 22 may be shaped in many different ways according to the same principle, so that it is free from compoundly curved surfaces.

Furthermore, the shell-like body must not necessarily include the arm-rests. According to Fig. 12, for example, the shell-like body 122 of a chair constitutes the seat 128 and the back-rest 134 thereof. Said shell-like body 122 has also an aperture 136 in its center portion extending from one side of the chair to the other. Furthermore, the surfaces of all areas of said shell-like body 122 are traced by straight-line generatrices, so that the shell-like body is free from compoundly curved surfaces. The shell-like body 122 of the chair shown in Fig. 12 is supported by a plurality of legs 220 which may be either separate pieces connected to the shell-like body 122 or may be members of a support connected to the shell-like body 122 in any suitable manner.

I have described preferred embodiments of my invention, but it is understood that this disclosure is for the purpose of illustration and that various omissions or changes in shape, proportion and arrangement of parts as well as the substitution of equivalent elements for those herein shown and described may be made without de-

parting from the spirit and scope of the invention as set forth in the appended claims.

What I claim is:

1. In an article of furniture: a shell-like body including a seat and a back-rest, said shell-like body having an aperture in its center portion and being composed of a plurality of surfaces adjacent to said aperture, at least a portion of said surfaces being curved, and all of said curved surfaces presenting unidimensional curves, in the direction of their curvature and being traced by a straight line generatrix perpendicular to the edge of the aperture at the point of intersection.

2. In an article of furniture: a shell-like body including a seat and a back-rest, said shell-like body having an aperture in its center portion and being composed of a plurality of surfaces adjacent to said aperture, a predetermined number of said surfaces being curved, the remainder of said surfaces being straight, and all of said curved surfaces presenting unidimensional curves, in the direction of their curvature and being traced by a straight line generatrix perpendicular to the edge of the aperture at the point of intersection.

3. In an article of furniture as claimed in claim 1, a piece of flexible material covering said aperture at the outside of said article and being attached to said shell-like body whereby a recess is formed capable of receiving a cushion and holding same in place.

4. In an article of furniture as claimed in claim 1, upholstery applied to said shell-like body, a portion of said upholstery covering said aperture at the outside of the article whereby a recess is formed capable of receiving a cushion and holding same in place.

5. In an article of furniture as claimed in claim 1, said shell-like body including a seat, a back-rest and arm-rests.

6. In an article of furniture as claimed in claim 1, said shell-like body including a seat, a back-rest and arm-rests, a portion of said arm-rests projecting laterally on each side of the article, and a separate supporting cradle, said shell-like body resting on said cradle only at its seat and at its laterally projecting portions of the arm-rests.

7. In an article of furniture as claimed in claim 1, said shell-like body including a seat, a back-rest and arm-rests, a portion of said arm-rests projecting laterally on each side of the article, upholstery applied to said shell-like body, a portion of said upholstery covering said aperture at the outside of said article and being attached to said shell-like body whereby a recess is formed capable of receiving a cushion and holding same in place, and a supporting cradle, said shell-like body resting on said cradle at its seat and at its laterally projecting portions of the arm-rests.

8. In an article of furniture as claimed in claim 1, said shell-like body having substantially uniform thickness throughout.

9. In an article of furniture as claimed in claim 1, said shell-like body being made from an integral blank of bendable sheet material bent into shape, said blank having a cut-out converging from its exterior towards its center and merging into a single aperture having side edges at first diverging away from and then converging towards the center of the blank and having an inner edge connecting said side edges, and the edges of said converging cut-out being in adjacent position when the blank is bent into shape forming said shell-like body.

10. In an article of furniture as claimed in

claim 1, said shell-like body being made from an integral blank of bendable sheet material bent into shape, said blank having a cut-out converging from its exterior towards its center and merging into a single aperture having side edges at first diverging away from and then converging towards the center of the blank and having an inner edge connecting said side edges, and the edges of said converging cut-out being in adjacent position and being connected with each other when the blank is bent into shape forming said shell-like body.

11. In an article of furniture as claimed in claim 2, said shell-like body being made from an integral blank of bendable sheet material bent into shape, said blank having a cut-out converging from its exterior towards its center and merging into a single aperture having side edges at first diverging away from and then converging towards the center of the blank and having an inner edge connecting said side edges, and the edges of said converging cut-out being in adjacent position when the blank is bent into shape forming said shell-like body.

12. In an article of furniture as claimed in claim 2, said shell-like body being made from an integral blank of bendable sheet material bent into shape, said blank having a cut-out converging from its exterior towards its center and merging into a single aperture having side edges at first diverging away from and then converging towards the center of the blank and having an inner edge connecting said side edges, and the edges of said converging cut-out being in adjacent position and being connected with each other when the blank is bent into shape forming said shell-like body.

13. In an article of furniture as claimed in claim 1, said shell-like body being made from a number of sectional blanks of bendable sheet material bent into shape and connected with each other at adjoining edges.

14. In an article of furniture as claimed in claim 1, said shell-like body consisting of an integral seamless piece of material.

15. In an article of furniture: a shell-like body including a seat, a back-rest and arm-rests, said shell-like body being made from a blank of bendable sheet material bent into shape, said blank having a cut-out converging from its exterior toward its center and merging into a single aperture having side edges at first diverging away from and then converging toward the center of the blank and having an inner edge connecting said side edges, the edges of said covering cut-out being in adjacent position when the blank is bent into shape forming said shell-like body, a portion of said arm-rests projecting laterally on each side of the article, and a separate supporting cradle, said shell-like body resting on said cradle only at its seat and at its laterally projecting portions of the arm-rests.

16. In an article of furniture: a shell-like body including a seat and a back-rest, said shell-like body being made from a blank of bendable sheet material bent into shape, said blank having a cut-out converging from its exterior toward its center and merging into a single aperture having side edges at first diverging away from and then converging toward the center of the blank and having an inner edge connecting said side edges, the edges of said converging cut-out being in adjacent position when the blank is bent into shape forming said shell-like body, a piece of flexible material covering at the outside of the article the

7

aperture formed in said shell-like body by the aperture of the blank, said piece of flexible material being attached to said shell-like body whereby a recess is formed capable of receiving a cushion and holding same in place.

17. In an article of furniture: a shell-like body including a seat, a back-rest and arm-rests, said shell-like body being made from a blank of bendable sheet material bent into shape, said blank having a cut-out converging from its exterior toward its center and merging into a single aperture having side edges at first diverging away from and then converging toward the center of the blank and having an inner edge connecting said side edges, the edges of said converging cut-out being in adjacent position when the blank is bent into shape forming said shell-like body, a portion of said arm-rests projecting laterally on each side of the article, upholstery applied to said shell-like body, a portion of said upholstery covering at the outside of the article the aperture caused in said shell-like body by said aperture of

8

the blank whereby a recess is formed capable of receiving a cushion and holding same in place, and a separate supporting cradle, said shell-like body resting on said cradle only at its seat and at its laterally projecting portions of the arm-rests.

EERO SAARINEN.

REFERENCES CITED

- 10 The following references are of record in the file of this patent:

UNITED STATES PATENTS

	Number	Name	Date
15	D. 81,313	Whitman	June 3, 1930
	232,496	Heywood	Sept. 21, 1880
	251,903	Lewis	Jan. 3, 1882
	1,548,488	Schibrowski	Aug. 4, 1925
	2,343,077	Parrish	Feb. 29, 1944
20	2,393,499	Flint	Jan. 22, 1946
	2,395,468	Eames	Feb. 26, 1946
	2,454,408	Roth	Nov. 23, 1948