

Nov. 21, 1961

G. NELSON ET AL

3,009,740

CHAIR

Filed May 15, 1957

2 Sheets-Sheet 1

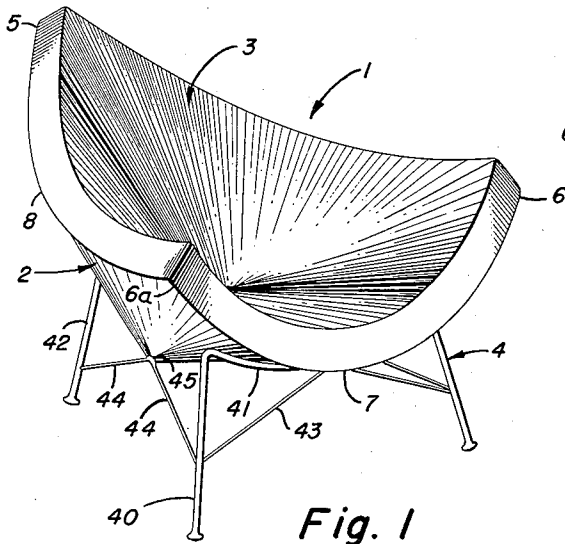

Fig. 1

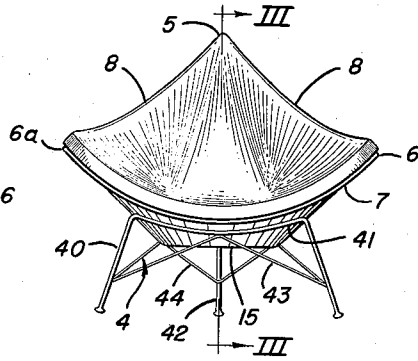

Fig. 2

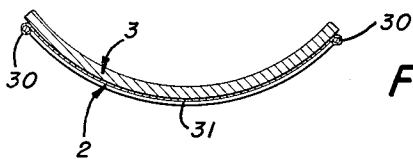

Fig. 5

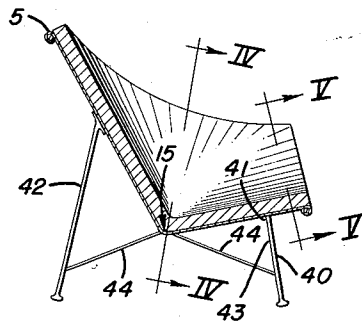

Fig. 3

Fig. 6

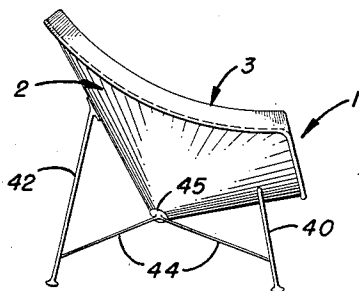
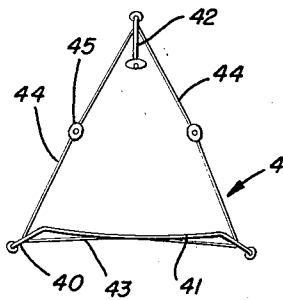

Fig. 7

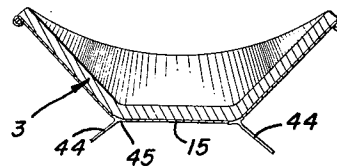

Fig. 4

INVENTORS
GEORGE NELSON
GEORGE MULHAUSER JR.
BY

Price and Sewell
ATTORNEYS

Nov. 21, 1961

G. NELSON ET AL

3,009,740

CHAIR

Filed May 15, 1957

2 Sheets-Sheet 2

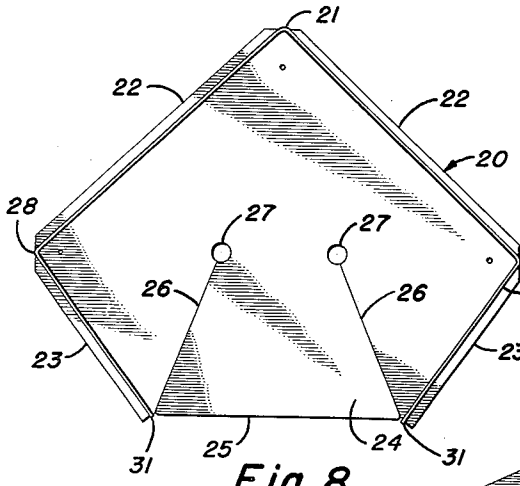

Fig. 8

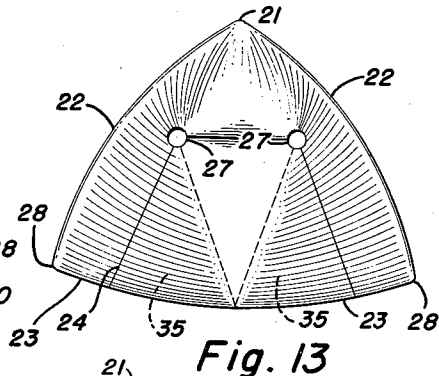

Fig. 13

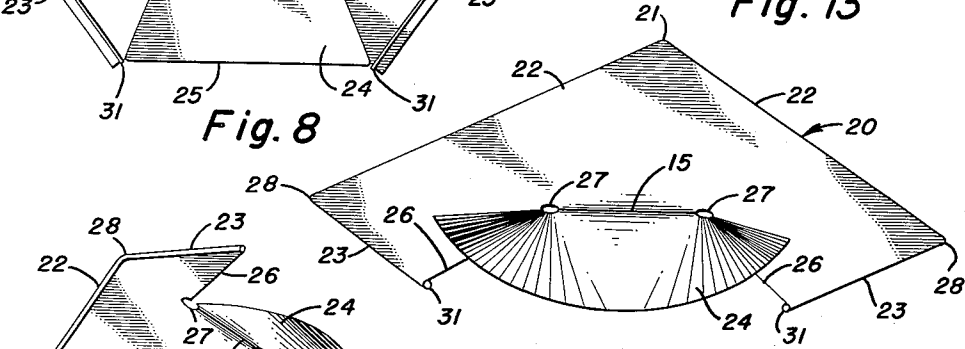

Fig. 9

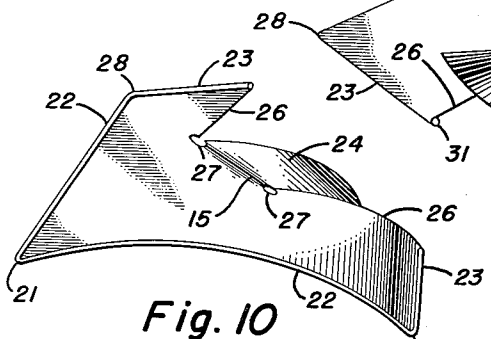

Fig. 10

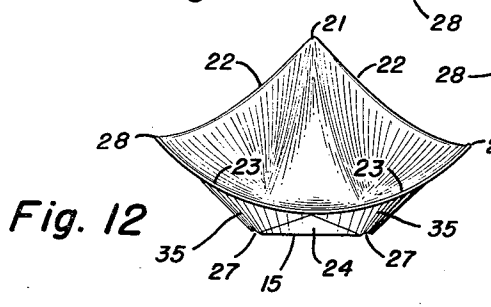

Fig. 12

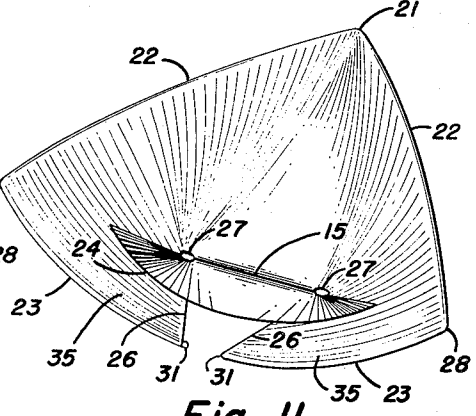

Fig. 11

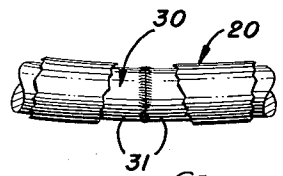

Fig. 14

INVENTORS
GEORGE NELSON
GEORGE MULHAUSER JR.
BY
Price and Fenwick
ATTORNEYS

1

3,009,740
CHAIR

George Nelson, Quogue, N.Y., and George Mulhauser, Jr., Paramus, N.J., assignors to Herman Miller, Inc., a corporation of Michigan

Filed May 15, 1957, Ser. No. 659,232
8 Claims. (Cl. 297-445)

This invention relates to furniture and more particularly to the design of a chair shell.

This invention is designed to provide a chair shell incorporating a maximum of comfort, strength and design balance. In the design of seating it is desired to provide a product which combines the qualities of comfort, durability and attractiveness of appearance. It is particularly desirable to create a design which will leave a definite and lasting impression on the viewer's mind. Many designs accomplish some of these purposes and a few all of them. However, they are exceedingly costly to fabricate and are for that reason largely impractical.

This invention provides a chair which accomplishes these purposes and is practical to fabricate without an excessive investment in tooling. It is strong, comparatively lightweight and exceedingly comfortable.

The supporting shell is so designed that its structure is in tension with the primary load carried by a peripheral rim. The whole central portion of the chair, including the seat and the lower portion of the back, are supported like a cradle or saddle between the leg structure. This permits a relatively thin gage material to support substantial loads since it is unnecessary to provide the wall thickness required to resist compressive buckling.

This invention also provides a chair form which firmly but comfortably supports the body of a person in seated position. It, however, has a flat portion of substantial width at the inner end of the seat, eliminating the tendency to cramp the user.

These and other purposes of this design will be understood by those acquainted by the problems of furniture design and manufacture upon reading the following specification and the accompanying drawings.

In the drawings:

FIG. 1 is an oblique view of the chair after upholstering.

FIG. 2 is a front elevation view of the chair after upholstering.

FIG. 3 is a sectional view taken along the plane III-III of FIG. 2.

FIG. 4 is a sectional view taken along the plane IV-IV of FIG. 3.

FIG. 5 is a sectional view taken along the plane V-V of FIG. 3.

FIG. 6 is a plan view of the space or standard for the chair.

FIG. 7 is a side elevation view of the chair.

FIG. 8 is a plan view of the flat pattern from which the chair shell is fabricated.

FIG. 9 is an oblique view of the pattern after the front apron has been bent concavely.

FIG. 10 is an oblique view of the pattern inverted on a die for bending the side edges to the curvature of the back and arms.

FIG. 11 is an oblique view of the pattern showing the remaining sides of the front of the pattern being drawn together under the apron.

FIG. 12 is a front elevation view of the shell after the front has been joined.

FIG. 13 is a plan view of the shell after the front has been joined.

FIG. 14 is an enlarged fragmentary view showing the joiner of the sides of the shell beneath the apron.

2

In executing this invention, I have provided a chair having a shell of generally triangular shape after forming. The apex of the triangular constitutes the upper center of the chair back while the lower corners of the triangle form the front corners or ends of the side arms. The sides extend from these corners to the apex serving as both the sides of the back and the arm rests of the chair. The leg opening of the shell is concave. Where the seat and back of the shell join, the two are bent along a straight laterally extending line generally parallel to the leg opening. This provides a wide, generally flat area at the rear of the seat and base of the back whereby the user is not cramped as would be the case were the chair laterally curved in this area.

The shell is formed by shaping a pentagonal sheet into a triangular shell with all three corners of the triangle curved upwardly from the center in a manner somewhat resembling a triangular segment of a sphere. The shell is secured to a tripod supporting the shell across the front and at a point slightly above the midway portion of the back. It also supports the shell at two neutral stress points of the shell representing the ends of the line of straight lateral joiner between the seat and the back. These points of attachment between the shell and base serve to stabilize the shell on the tripod and to strengthen the tripod itself.

Referring specifically to the drawings, the numeral 1 indicates a chair having a shell 2 and a cushion or upholstery 3 all supported by a tripod 4. The shell 2 is triangular in shape with the apex 5 of the triangle forming the top of the back and centered between the sides of the shell. The lower corners of the triangle form the front corners 6 and 6a of the shell. The base of the triangle forms the front edge 7 of the shell. The sides of the triangle form the sides 8 of the shell, with their forward portions serving as the arm rests and their rearward portions as the sides of the back.

It will be noted that the basic shape of the shell is formed by three lines, each of which in one portion functions as one part of the chair and in another portion as another part of the chair. Thus, the front edge is in its central portion the forward end of the seat and its outward portion functions as the forward ends of the arms.

Along the centerline of the chair the seat portion of the shell is straight and slopes back to the line of juncture 15 between the seat and the back. Along the shell's centerline, the back is straight and extends upwardly from the juncture 15. Beyond the ends of the juncture 15 both the seat portion and the back portion become increasingly concave. Laterally of the shell, the upper portion of the back portion and the forward portion of the seat are concave. However, both the seat and the back, as they approach the juncture 15, become less concave until along the line of juncture they are flat. The line of juncture extends approximately one-third the width of the chair and is centered about the center line of the shell.

The form of the shell is that which is generated by suspending a triangular sheet of material at each of its corners with the apex held substantially above the lower corners and then placing a weight in the form of a straight rod in the sheet at approximately the geometric center of the triangle. This rod is laid parallel to the base of the triangle and has a width of approximately one-third of the length of the triangle's base. This reasonably approximates the load distribution of the body of a person seated in a chair having a backwardly inclined seat. The major portion of the load is applied adjacent the juncture of the back and seat.

The straight juncture line 15 provides a wide portion of flat supporting area at the rear of the seat. This eliminates the feeling of being cramped when seated in the

chair. If this area were made concave, the shell would tend to squeeze the user's body toward the center and thereby give the feeling of being cramped. However, at the leg opening and the upper portion of the back the concavity of the shell structure provides comfort. It tends to center the person in the chair and gives restful support to the body which does not require the body to change its shape to find more than a single point of contact with the unit.

Referring to FIGS. 8-12, the fabrication of this chair from a flat sheet of material such as a sheet of metal will be described. FIG. 8 shows a flat pattern of a sheet 20 having the shape of a pentagon. This sheet has an apex 21 which will become the apex 5 of the shell. It has a pair of sides 22 which will become the sides 8 of the shell. It has a pair of short, inclined sides 23 which together will become the front edge 7 of the shell. It also has an apron 24 having a front edge 25 which will overlap a substantial portion of the sides 23 and thus also become a portion of the shell's front edge 7.

The apron 24 is a symmetrical trapezoid in shape. It is separated along its lateral sides from the remainder of the sheet 20 by a pair of severance lines 26. These converge toward the apex 21, terminating in a circular cut-out 27 located somewhat to the rear of a line drawn between the corners 28. The corners 28 will become the corners 6 and 6a of the shell. As an example of a set of working proportions for the pattern, if the sides 22 are 41 inches and sides 23 are 22 inches and the distance from the apex 21 to the front edge 25 of the apron 24 is 45 inches, the circular openings 27 should be located approximately 7 inches from the center line of the pattern and approximately 27½ inches forward of the apex 21. This provides an apron of 31 inches in width at the front edge 25. These dimensions are merely exemplary and not to be considered as a limitation upon the scope of this invention.

The next step in forming the shell is to roll the apron 24 into a generally concave shape as illustrated in FIG. 9. In so doing, the apron is made to rise above the plane of the sheet 20. The fold line or the line of bending at the base of the apron is straight and extends between the openings 27. It becomes the juncture 15 between the back and seat of the finished shell.

Either before or after the shaping of the apron, the sides 22 and 23 of the sheet are reinforced by a rod 30. This rod is secured to the sheet by wrapping the edges of the sheet 20 down around it so that the rod is rolled into the underface of the edge of the sheet. The ends 31 of the rod 30 are chamfered for purposes which will appear more fully hereinafter.

After the rod 30 has been secured and the apron 24 has been rolled into a generally concave shape, the sheet 20 is placed upside down on a suitable form or die and the two long side edges 22 are bent to the desired curvature. This step is illustrated in FIG. 10 wherein the adjacent edge has been so bent while the remote one remains straight. This bending can either be done manually over a suitable form or between dies.

The ends 31 of the rod 30 are then brought together under the apron 24 by curving and bending the remainder of the front portion of the sheet and telescoping a major portion of the sides 23 under the apron. This pulling together of the corners 28 of the shell gives to both the upper portions of the back and the forward portions of the seat a concave shape. They both tend to enter a somewhat gently and smoothly curved form. It will be seen that the front portion of the shell tends to have the same shape as that of the apron 24 which previously had been rendered generally concave. In drawing together the ends of the sides 23, the pivot points about which the shell is twisted are the two circular openings 27 (FIG. 11). It will be noted that when the apron 24 was formed it was bent up from the remainder of the sheet along a straight line between the openings 27, thus forming the

beginning of the line of juncture 15 between the seat and the back. This line remains straight throughout the forming of the shell and it, together with the openings 27, become the axis about which the entire shell is pulled together and rendered generally concave in form. Care is taken in forming the shell to maintain this axis in its original, straight condition.

When the ends 31 on the rod have been brought together, they are welded or braised to form a secure joint at the front edge of the shell (FIGS. 12 and 14). It will be seen that the panels of the sheet which lay between the severance lines 26, the sides 23, and the corners 28, and identified by the reference numerals 35 in FIGS. 11, 12 and 13, are partially telescoped under the apron 24, leaving a triangular opening between them. This opening has its base along the fold or juncture line 15, its apex at the front edge of the shell and its side running from this apex back to the circular openings 27. This opening is covered by the apron which is firmly secured to the panels 35 by suitable means such as welding. After the shell has been formed to shape, the holes 27 are filled as by welding.

It will be seen that a shell formed in this manner can be strong even though built of relatively light gauge metal since all portions of the shell except that immediately adjacent the juncture line 15 is placed under tension with no part of the shell acting in compression. Since many materials will stand high tension loading even though of thin gauge, this shell is particularly adapted to their use. Thicker and heavier gauge materials are necessary only where the loading is in compression and it is necessary to provide a substantial moment of inertia to prevent oil canning or buckling. Further, when the chair is in use, all of the loads remain in tension. The loadings in the area around the juncture line 15 are also expressed in tension since that becomes a saddle portion suspended or swung between supports. Any attempt to spread the shell's front corners 6 and 6a (corners 28 of the sheet 20) will be strongly resisted not only by the concave portions of the shell between the corners but by the rim or periphery of the shell being placed in tension. The openings 27 are designed to be at a point of neutral stress in the shell. The main stresses generated within the shell, even when occupied, are carried by the peripheral portions of the shell with the zone around the openings 27 sustaining only minor stress loads.

The tripod 4 for supporting the shell is designed to provide support at the maximum load points and to so stress the shell that the whole central portion of the shell is at all times in tension. The tripod 4 consists of an inverted generally U-shaped front leg 40, the upper bar 41 of which is concave to fit snugly against the exterior of the shell adjacent its front edge 7. The rear leg consists of a single standard 42 sloping upwardly and forwardly to contact the back at a point slightly above midway between the apex 5 and the juncture line 15.

The front leg is cross-braced by rods 43. The front leg and the rear leg are also joined by rods 44. These rods 44 incline upwardly from each of the legs and at a point approximately midway between the legs have an attachment button 45. The attachment button provides means by which these rods are secured to the shell 2 almost at the openings 27. This is an important feature of the tripod because it provides a structural brace for the shell at the maximum point of sway between the legs but at a point where the rods will be subjected to tension only. This arrangement steadies both the shell and the tripod legs. The weight of the shell is supported entirely by the legs 40 and 42, the rods 44 serving only as tension bracing. The tie between the rods 44 and the shell prevents any backward or rearward movement of the shell by reason of its rocking about the legs. For the purpose of securing the legs to the shell, studs may be provided on the legs. These extend through the shell and are attached by nuts on the inside. The same fastening arrangement may be used for securing the attachment but-

tons 45 on both the rods 44 and the rear leg 42. It will be recognized that other means of attachment may be used such as by welding studs to the shell and attaching them to the legs or, if desired, the legs and the shell could be welded together. This latter is less desirable because it prevents shipment of the shells and tripods in knock-down condition. The specific means of attachment between the legs and the shell is unimportant to this invention.

The shape of the chair is specifically designed to provide a shell having a balanced stress distribution. The shape is that which a flexible triangular free-form would assume if suspended from the corners with the back corner held above the front corners and with the load substantially concentrated along the juncture 15. This juncture line 15 extends laterally of the chair and gives the chair the shape the free-form would assume when suspended as described and a rod-shaped weight rests in the free-form at a point spaced from the base of the triangle approximately one-third the height of the triangle. The length of this rod would be approximately one-third that of the base of the triangle and would be centered about the perpendicular of the triangle. The shape assumed by such a flexible free-form is that in which the loadings in the free-form are balanced. Since the weight of a person seated in the chair is substantially concentrated in the same manner, the shape of the chair causes the loads to be balanced in approximately the same manner. The fact that the legs do not support the shell at the corners of the triangle does not change this fact. The area of the shell within the outline of the tripod acts in the manner described just as if the triangle were of smaller dimensions and includes the entire area of applied loading.

The interior of the shell is padded with upholstery such as the cushion 3. This may take any of many forms but in the particular form illustrated it consists of a fabric covered cushion having a suitable resilient internal body such as sponge rubber. The perimeter of the fabric has a spring, elastic band or draw string incorporated into it, forming a band. This band is placed beneath the rolled edge of the shell, wrapping the edge of the upholstery over the edge of the shell. This securely anchors the cushion 3. The cushion is preferably secured to the shell in several places by suitable means such as snap fasteners to prevent the cushions from becoming displaced while in use. It will be recognized that various other forms of upholstery may be used with this chair without in any way departing from the principles of this invention. It will also be recognized that other forms of attachment may be employed.

While the forming of this chair from a sheet metal blank has been described in detail, it will be recognized that the shell could be molded from suitable materials such as a reinforced plastic or a ligneous or other type of fibrous material having a high strength resinous binder. Preference is given to the metal shell because it requires a substantially lesser investment in tooling than does the plastic type shell because of the latter's initial high mold cost. It is, however, to be understood that so far as the chair is concerned, my invention is considered to embrace the molded form of chair shell as well as that which is made from sheet metal by the particular method heretofore described.

It will be recognized that while I have described a preferred embodiment of my invention, modifications may be made in the chair. Such of these modifications as embrace the principles of my invention are to be considered as included in the hereinafter appended claims unless these claims by their language expressly state otherwise.

I claim:

1. A shell for a chair, said shell being triangular and generally concave with the apex of said triangle being substantially above the other corners thereof; said shell having the shape assumed by a freely flexible triangular web suspended from each of its corners with its apex

elevated substantially above each of its other corners and a rod-shaped weight having a length approximately one-third that of the base of the triangle supported in said web parallel to said base, centered about the perpendicular of said triangle and spaced from said base approximately one-third the height of said triangle whereby the forces in said shell are balanced throughout its entire area.

2. A chair comprising: a shell, said shell being triangular and generally concave with the apex of said triangle being substantially above the other corners thereof; said shell having the shape assumed by a freely flexible triangular web suspended from each of its corners with its apex elevated substantially above each of its other corners and a rod-shaped weight having a length approximately one-third that of the base of the triangle supported in said web parallel to said base centered about the perpendicular of said triangle and spaced from said base approximately one-third the height of said triangle whereby the forces in said shell are balanced throughout its entire area; a tripod for supporting said shell; said tripod having legs mounted to said shell adjacent each of the lower corners thereof and at a point intermediate the geometric center of said shell and its apex.

3. A chair comprising: a shell, said shell being triangular and generally concave with the apex of said triangle being substantially above the other corners thereof; said shell having the shape assumed by a freely flexible triangular web suspended from each of its corners with its apex elevated substantially above each of its other corners and a rod-shaped weight having a length approximately one-third that of the base of the triangle supported in said web parallel to said base centered about the perpendicular of said triangle and spaced from said base approximately one-third the height of said triangle whereby the forces in said shell are balanced throughout its entire area; a tripod for supporting said shell; said tripod having legs mounted to said shell adjacent each of the lower corners thereof and at a point intermediate the geometric center of said shell and its apex; said tripod having cross braces between the leg mounted to said shell at a point intermediate the geometric center of said shell and its apex and the other legs thereof, said cross braces being secured to said shell at the ends of the depression formed by said rod-shaped weight.

4. A triangular standard for supporting a chair shell, said standard comprising: a back leg sloping inwardly and upwardly; means on the upper end of said leg for securing it to said shell; a pair of laterally spaced front legs; a brace member generally triangularly shaped in plan view and secured at each of its corners to corresponding legs; the portion of said brace member between each of said legs being upwardly arched toward the midpoint thereof; attachment means on each of said brace members at the highest points thereof between said front legs and said rear leg; said attachment means adapted to secure said brace member to said shell.

5. A triangular standard for supporting a chair shell, said standard comprising: an inwardly and upwardly inclined rear leg; means on the upper end of said leg for securing it to said shell; a front support of inverted U-shape and having a leg on each end; the central portion of said front support being concave; a brace member generally triangularly shaped in plan view and secured at each of its corners to corresponding legs; the portion of said brace member between each of said legs being upwardly arched toward the midpoint thereof; said brace member being secured to said front support midway between said legs of said front support; attachment means on said brace member at the highest points thereof between each of said legs of said front support and said rear leg; said attachment means adapted to secure said brace member to said shell whereby the shell serves as the sole rigid connection between the upper ends of said legs and said attachments on said brace member between said front and rear legs.

6. A shell for a chair, said shell being triangular and

7

generally concave with the apex of said triangle being substantially above the other corners thereof; said shell having the shape assumed by a freely flexible triangular web suspended from each of its corners with its apex elevated substantially above each of its other corners and a rod-shaped weight having a length approximately one-third that of the base of the triangle supported in said web parallel to said base, centered about the perpendicular of said triangle and spaced from said base approximately one-third the height of said triangle whereby the forces in said shell are balanced throughout its entire area; a reinforcing member secured to the peripheral margin of said shell and surrounding said shell on the lower side thereof.

7. A chair body comprising: a shell, said shell being triangular and generally concave with the apex of said triangle being substantially above the other corners thereof; said shell having the shape assumed by a freely flexible triangular web suspended from each of its corners with its apex elevated substantially above each of its other corners and a rod-shaped weight having a length approximately one-third that of the base of the triangle supported in said web parallel to said base, centered about the perpendicular of said triangle and spaced from said base approximately one-third the height of said triangle whereby the forces in said shell are balanced throughout its entire area; a reinforcing member secured to the perimeter of said shell and surrounding said shell; a padded cushion covering the entire inner and upper surface of said shell and extending to each of the corners thereof; and means securing said cushion to said shell.

8. A chair comprising: a shell, said shell being triangular and generally concave with the apex of said triangle being substantially above the other corners thereof; said shell having the shape assumed by a freely flexible triangular web suspended from each of its corners with its apex elevated substantially above each of its other cor-

8

ners and a rod-shaped weight having a length approximately one-third that of the base of the triangle supported in said web parallel to said base, centered about the perpendicular of said triangle and spaced from said base approximately one-third the height of said triangle whereby the forces in said shell are balanced throughout its entire area; a reinforcing member secured to the perimeter of said shell and surrounding said shell; a padded cushion covering the entire inner and upper surface of said shell and extending to each of the corners thereof; means securing said cushion to said shell; a tripod for supporting said shell, said tripod having legs mounted to said shell adjacent each of the lower corners thereof and at a point intermediate the geometric center of said shell and its apex.

References Cited in the file of this patent

UNITED STATES PATENTS

D. 147,671	Kirkpatrick	Oct. 14, 1947
D. 170,791	Bertoia	Nov. 10, 1953
D. 171,176	Yellen	Dec. 22, 1953
1,615,358	Chubb	Jan. 25, 1927
1,697,789	Snyder	Jan. 1, 1929
1,759,645	Janke et al.	May 20, 1930
2,480,018	Greenberg	Aug. 23, 1949
2,483,223	Moss	Sept. 27, 1949
2,525,670	Hamilton	Oct. 10, 1950
2,541,835	Saarinen	Feb. 13, 1951
2,606,517	Dunlop	Aug. 12, 1952
2,763,318	Bertoia	Sept. 18, 1956
2,764,228	Donohue	Sept. 25, 1956
2,818,107	Thaden	Dec. 31, 1957
2,831,534	Thaden	Apr. 22, 1958

FOREIGN PATENTS

1,126,483	France	July 30, 1956
1,136,531	France	Dec. 29, 1956